

R Series Reach Truck

R14/R16/R20

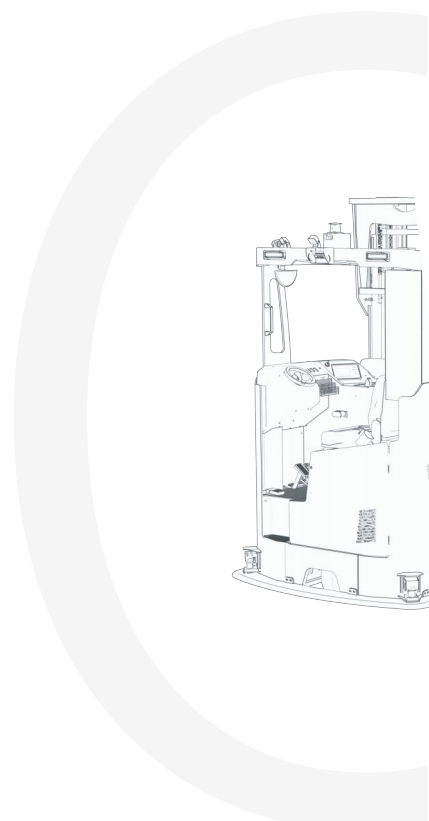

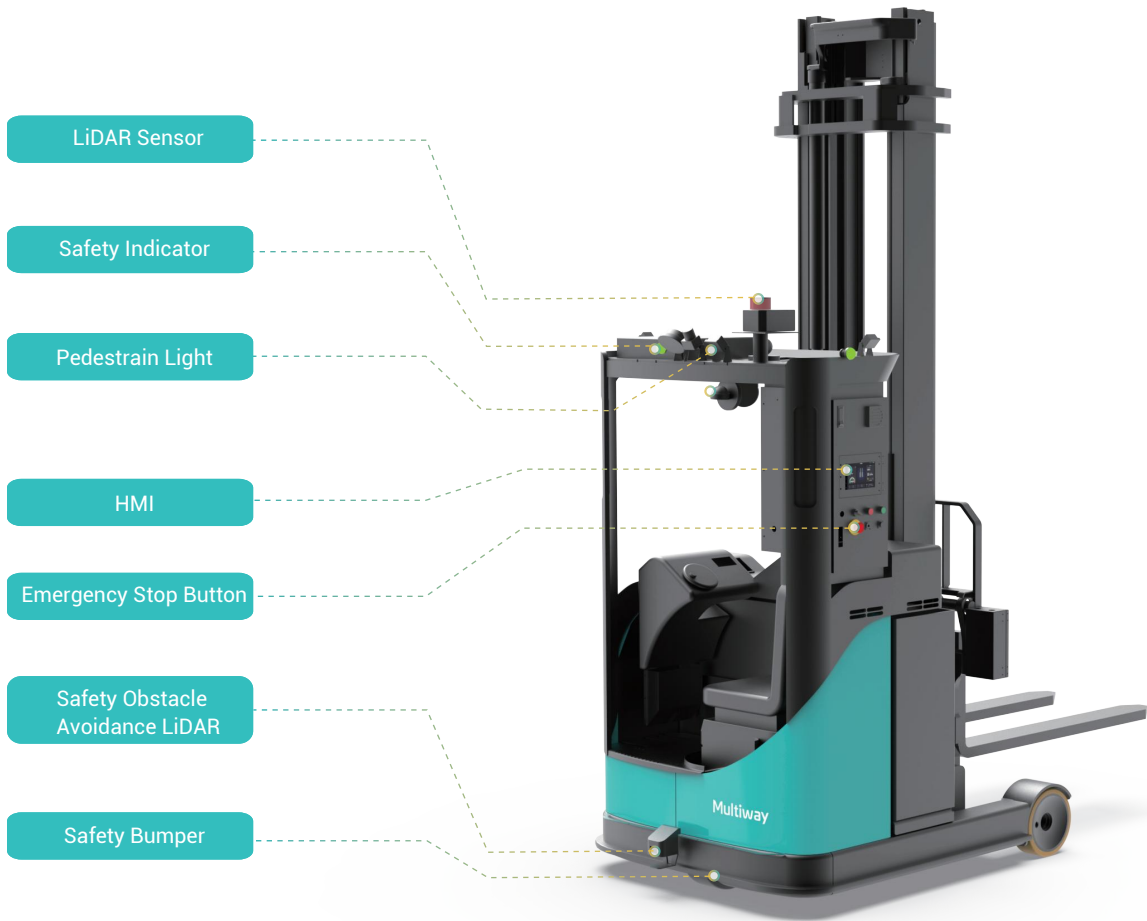

Introduction

The R-series forward-moving unmanned forklift is suitable for automatic intermediate transfer and handling of goods between different positions for various types of entering fork-type carriers. It supports a maximum load of 2500kg and a lifting height of up to 9500mm. It can meet the requirements of high stacking operations, with advantages such as fast operation speed, good climbing ability, and strong compatibility with carriers. It is widely used in scenarios such as line integration, goods stacking, shelf access, and automatic loading and unloading.

Features



Environment Adaptive

With laser navigation and positioning, there's no need to renovate the on-site environment.



Highly Intelligent

A whole range of functions such as mapping, path planning, auto-charging, and intelligent operations for various scenarios.



Non-stop pallet position detection

Visual perception non-stop pallet pose identification can realize fast and accurate pick-and-place of goods.



Intelligent Safety

Comprehensive fault self-detection
360° obstacle avoidance and sound & light warning.

Scenarios



Cold Storage Applications

Breaking through the -25°C automation handling requirements, adapting to high and low-temperature switching operations, the series of cold storage vehicle models comprehensively meet various logistics scenarios, including stacking of goods in cold storage and high-level access.



Automatic (un)loading

Compatible multiple models (wing gate, tail gate).
Compatible with multiple sizes of cargo (automatic allocation).



Cage Stacking

The motion trajectory is dynamically constructed to achieve accurate stacking of up to 6 layers of material cages. It is also equipped with safety technology detection to ensure operating safety.



High-level Access

The maximum lifting height can reach 10m, enabling quick identification and correction of positional deviations, precise identification of cargo conditions, and avoiding hazards in high-level shelf operations.

R Series R14/R16/R20 Reach Truck



Specifications

Model	R14	R16	R20
Navigation	Laser/ Sky Navigation/ Mixed Navigation		
Communication	Wi-Fi/ 5G/ Optical Communication		
Driving Features	Forward, Reverse, and Turn		
Control Mode	Auto/Manual		
Rated Load (Q)	1400 kg	1600 kg	2000 kg
Load Center (C)	600mm		
Weight (Including battery)	3010~3390kg		3375~3650 kg
Turning Radius (Wa)	1705 mm	1710mm	1940 mm
Aisle Width	3200 mm		3250 mm
Maximum Lifting Height	9000mm	9500 mm	
Dimensions (L×W×H)	2550x1455x (2350~3910) mm		2600x1550x4930 mm
Fork Dimensions (l×exs)	1150x100x40 mm		1150x100x45 mm
Fork Rack Width (b2)	790 mm		830 mm
Fork Spread Outer (b3)	296~690 mm	316~710 mm	
Minimum Height of Fork From the Ground (h6)	50±5 mm	55±5 mm	
Positioning precision (Center of bearing wheel)	±20 mm		
Obstacle Clearing Capability	≤10 mm		
Cross-Groove Capability	≤30 mm		
Max Driving Speed (No Load/Full Load)	1.5m/s / 2m/s		
Battery Voltage/Capacity (V/Ah)	48V/450AH		
Run time	8~10h		
Battery Life	Complete charge-discharge 2500 times ≥70%		

Basic Parameter

Movement Specifications

Battery Specifications

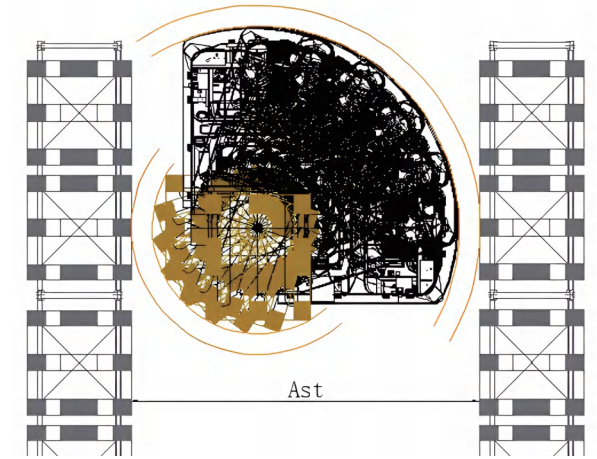
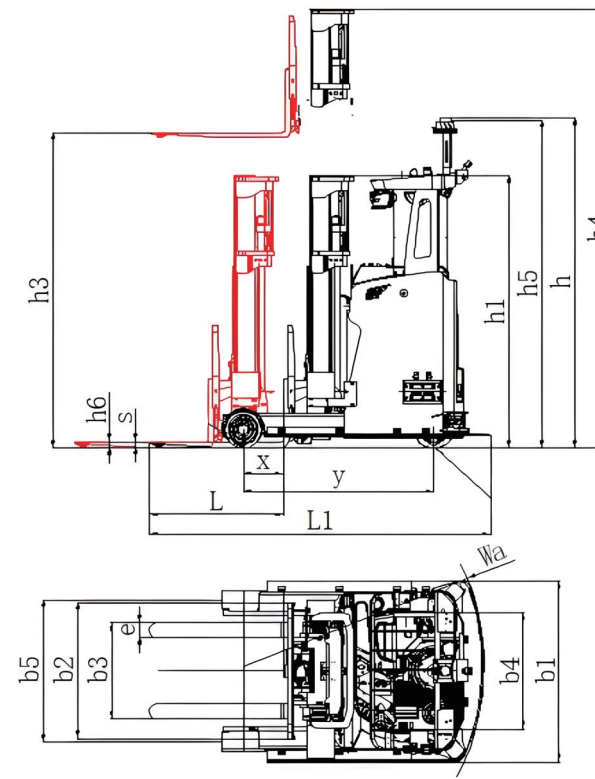

Aisle Width				
Model	R14	R16	R20	
1000 ↑ x1000mm Pallet	AST(mm)	3050	3050	3100
1000 ↑ x1200mm Pallet		3200	3200	3250
1200 ↑ x1200mm Pallet		3250	3250	3300

Triplex Mast

R14HD -6355 to 8555mm; R16HD -6355 to 11455mm; R20-4355 to 11455mm; R20N-4355mm to 9455mm

Lift	h ₃	4355	4655	5155	5755	6355	6655	6955	7255	7555	7955	8255	8555	8955	9155
Free Lift	h ₂	1261	1627	1627	2061	2081	2081	2581	2581	2581	2581	2581	3081	3081	3081
Height of mast, lowerd	h ₁	2110	2476	2476	2910	2930	2930	3430	3430	3430	3430	3430	3930	3930	3930
height of mast, extended	h ₄	5095	5395	5895	6495	7139	7439	7739	8039	8339	8739	9039	9339	9739	9939

R14HD -6355 to 8555mm; R16HD -6355 to 11455mm; R20-4355 to 11455mm; R20N-4355mm to 9455mm

Lift	h ₃	9455	9655	9955	10155	10455	10655	10955	11155	11455
Free Lift	h ₂	3081	3081	3581	3581	3581	3581	4081	4081	4081
Height of mast, lowerd	h ₁	3930	3930	4430	4430	4430	4430	4930	4930	4930
height of mast, extended	h ₄	10239	10439	10739	10939	11239	11439	11739	11939	12239

Note: In the real-time update of product parameters, the above parameters are for reference only and shall prevail.

Attachment



Pitch



Traverse



Automatic fork spread adjustment



Overweight alarm

Customize



Cold chain

Carrier



2-way pallet

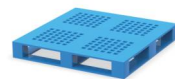

4-way pallet



Cage



Cart

Load Curve

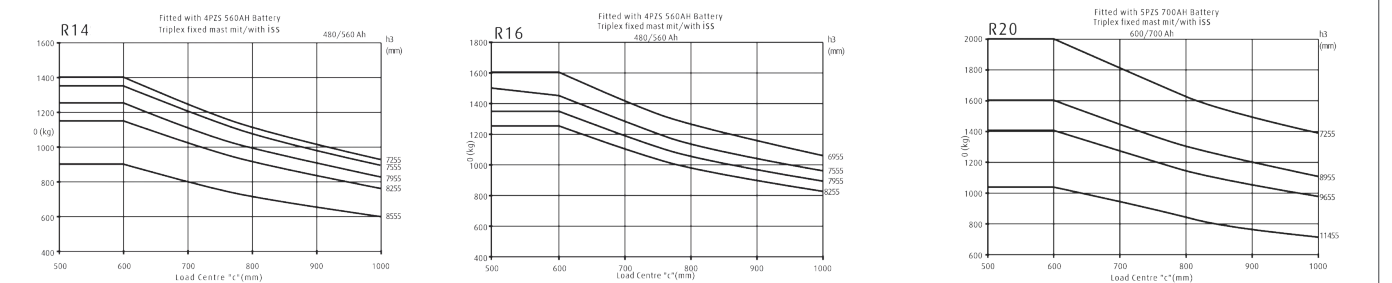

Comprehensive safety protection:

Acoustic+physical, 360° protection

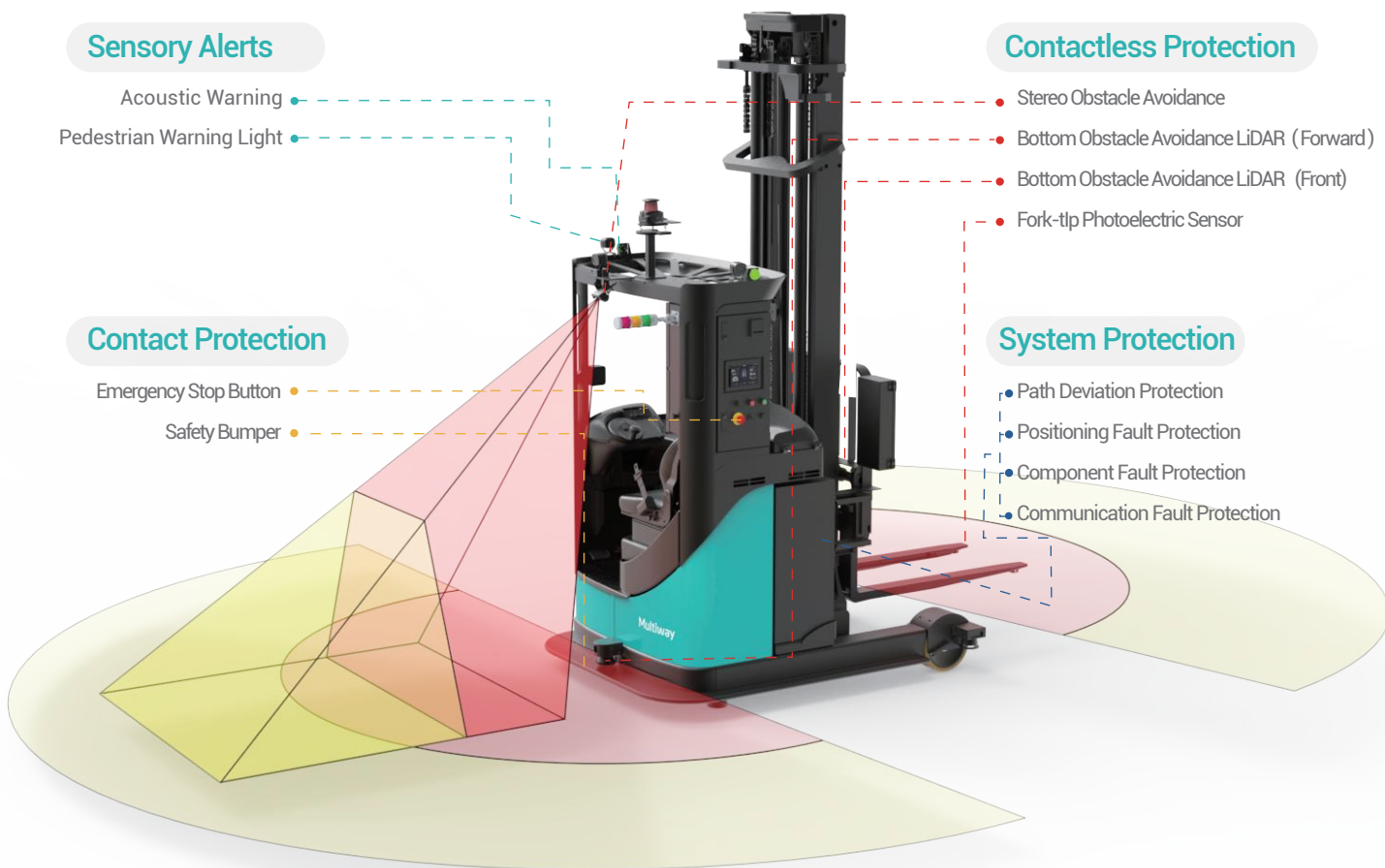

Point Cloud Obstacle Avoidance:

The forward simulation algorithm can measure the distance to obstacles, autonomously adjust the moving speed, ensure the vehicle accelerates and decelerates smoothly without sudden changes in speed.

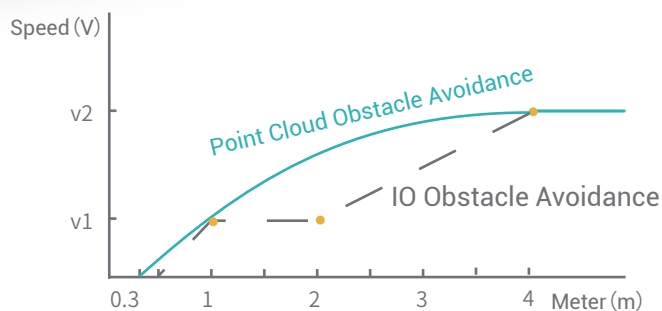

Contact Us

Offices:

USA · Atlanta | Japan · Tokyo | Korea · Seoul

Germany · North Rhine-Westphalia

China · Shenzhen

Official website: www.mw-r.com

Email: sales@mw-robot.com

Subscribe to get the latest Multiway Robotics news