

Multiway Robotics



Environment Adaptive

With laser navigation and positioning, there's no need to renovate the on-site environment.



Non-stop pallet pose identification

Visual perception non-stop pallet pose identification can realize fast and accurate pick-and-place of goods.



Highly Intelligent

A whole range of functions such as mapping, path planning, auto-charging, and intelligent operations for various scenarios.



Intelligent Safety

Comprehensive fault self-detection 360° obstacle avoidance and sound & light warning.



Contact Us

Offices:

USA · Atlanta | Japan · Tokyo | South Korea · Seoul
Germany · North Rhine-Westphalia
China · Shenzhen

Hotline: + 86 133 9286 4873

Official website: www.mw-r.com

Email: sales@mw-robot.com

Pallet Stacker MW-SL14

Specifications

	Model	SL14
Basic Parameter	Navigation	Laser/ Sky Navigation/ Mixed Navigation
	Communication	Wi-Fi/ 5G/ Optical Communication
	Driving Features	Forward, Reverse, and Turn
	Control Mode	Auto/Manual
	Rated Load (kg)	1400kg
	Load Center (mm)	600
	Weight (Including battery) (kg)	930
	Turning Radius (mm)	1140
	Aisle Width (mm)	2350
	Maximum Lifting Height (mm)	2500
	Dimensions L×W×H (mm)	1730x1010x (1990/2140/2290/2350)
	Fork Dimensions l×exs (mm)	1150x170x60
	Fork Outer Space (mm)	560/620/680
Movement Specifications	Positioning precision/ Stop Angle (Center of bearing wheel) (mm/ °)	±10/±1°
	Obstacle Clearing Capability	≤10
	Climbing Capacity	≤3° (5%)
	Cross-Groove Capability (mm)	≤30
	Max Driving Speed (m/s)	1.38
	Battery Voltage/Capacity (V/Ah)	24V/200Ah
Battery Specifications	Charging Mode	Auto/Manual
	Run time	6~8h
	Battery Life	Complete charge-discharge 2500 times ≥70%
	Battery Type	Lithium Iron Phosphate

Note: In the real-time update of product parameters, the above parameters are for reference only and shall prevail.

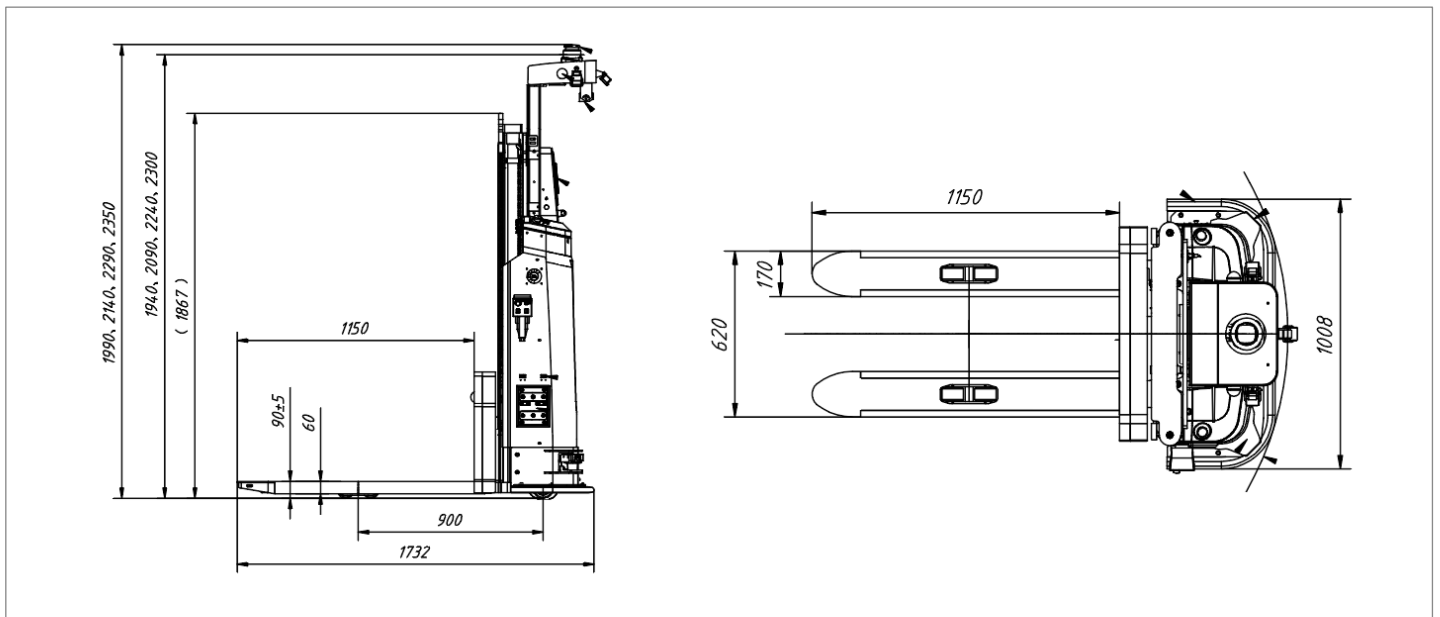

Subscribe to get the latest Multiway Robotics news

[Multiway Robotics](#)

[Search](#)

